



AFWERX • SPACEWERX

**SpaceWERX Open Topic 25.5 Direct to Phase
II (D2P2) AMA**

PRESENTER VANESSA ALMANZA

SpaceWERX Open Topic

*Information current as of January 2025

Distribution A. Approved for public release; distribution unlimited. AFRL-2025-0302

Rules of Engagement

1. Call is recorded and will be available on SpaceWERX.us
2. No classified/proprietary Information
3. Post questions in the Q&A section (not via chat)

All information is subject to change. The final, authoritative source of info & requirements is the solicitation instructions found on DSIP.

To access the Q&A function, please click the Activity Icon



in the bottom right hand corner, then select Q&A from the menu.

Your question will be answered verbally or by text in the **CHAT** window. If you see a similar question already in the Q&A queue, please just upvote that question vs. adding the same one. If your question is dismissed without a response, it likely means the question has already been asked and answered verbally or in the chat.

We will do our best to answer all of your questions pertaining to today's topic.
All off topic questions will not be answered.

The screenshot shows the 'Activities' menu in Google Meet. At the top, there are 'Featured add-ons' including Confluence, Polly, and Lucidspark. Below that, under the 'GOOGLE' section, several features are listed: Breakout rooms, Live streaming, Polls, Q&A (highlighted with a red box), Recording, and Transcripts. The Q&A option is described as 'Give everyone an easy way to ask questions'. A plus sign icon is visible at the bottom right of the menu.

Department of the Air Force (DAF) Open Topic Solicitation

Topics are truly “open” and agnostic of industry, technology, or problem area.

We are seeking...

- Innovative, dual-use tech solutions (i.e. applicable to defense and non-defense)
- Clear potential to solve a DAF mission need (USAF, USSF)
- Capability to prototype under an accelerated schedule
- Ability to scale and grow the industrial base for defense
- Commitment from an empowered DAF end-user and customer
- Applied R/R&D efforts rather than “front-end” or basic research

Upcoming Space Open Topic Cycles

Phase I solicitations include SBIR and STTR / D2P2 solicitations include SBIR only

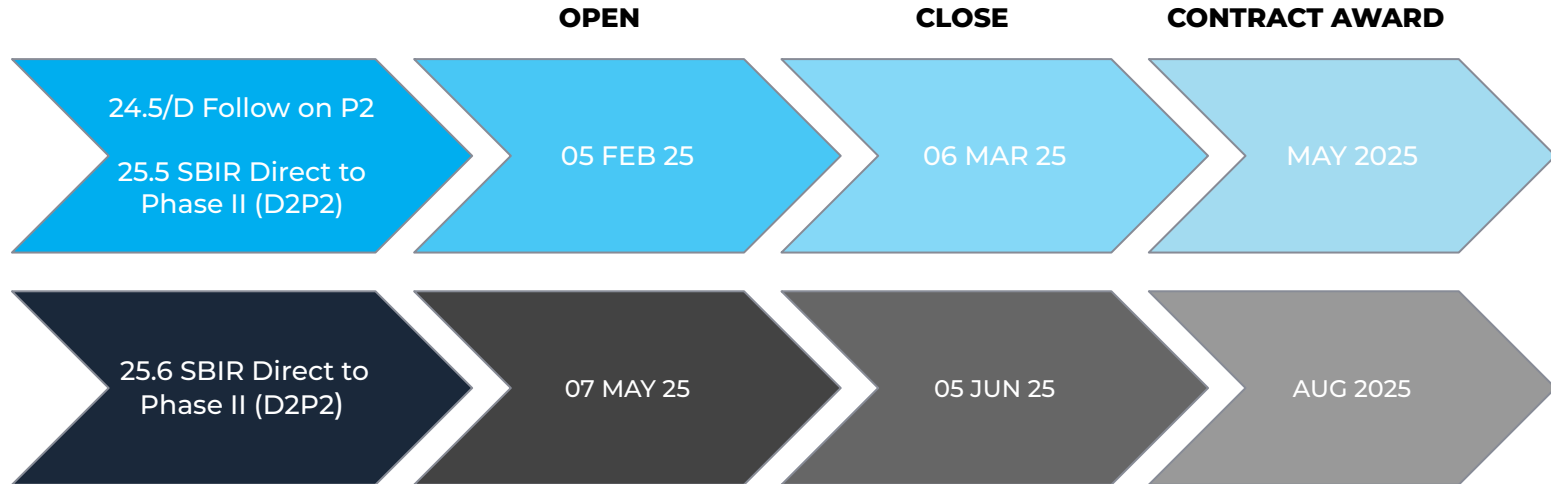

Phase I Feasibility Study	<ul style="list-style-type: none">• SBIR up to \$75K per award• STTR up to \$110K per award• Three month period of performance	Phase II Prototype	<ul style="list-style-type: none">• SBIR up to \$1.25M per award• STTR up to \$1.8M per award• 21 month period of performance
-------------------------------------	--	------------------------------	---

Solicitations vs. Topics*

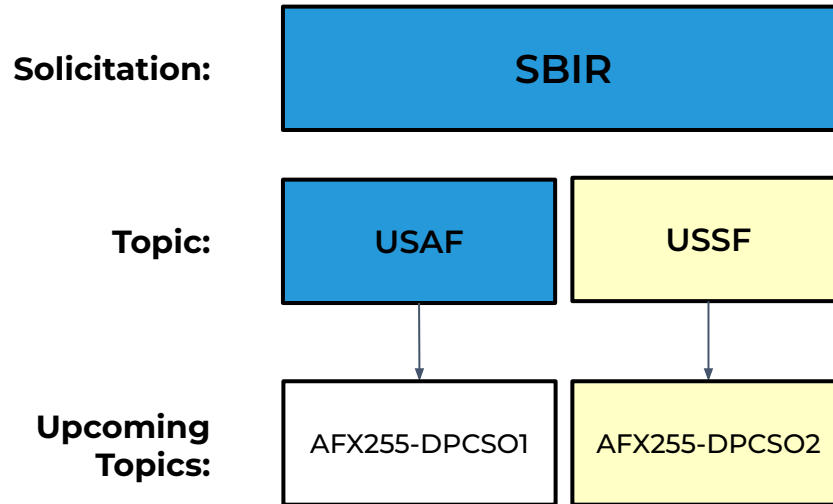

D2P2 EXAMPLE

*Only applies to Open Topic. Specific Topic uses a different framework.

Evaluation Rules

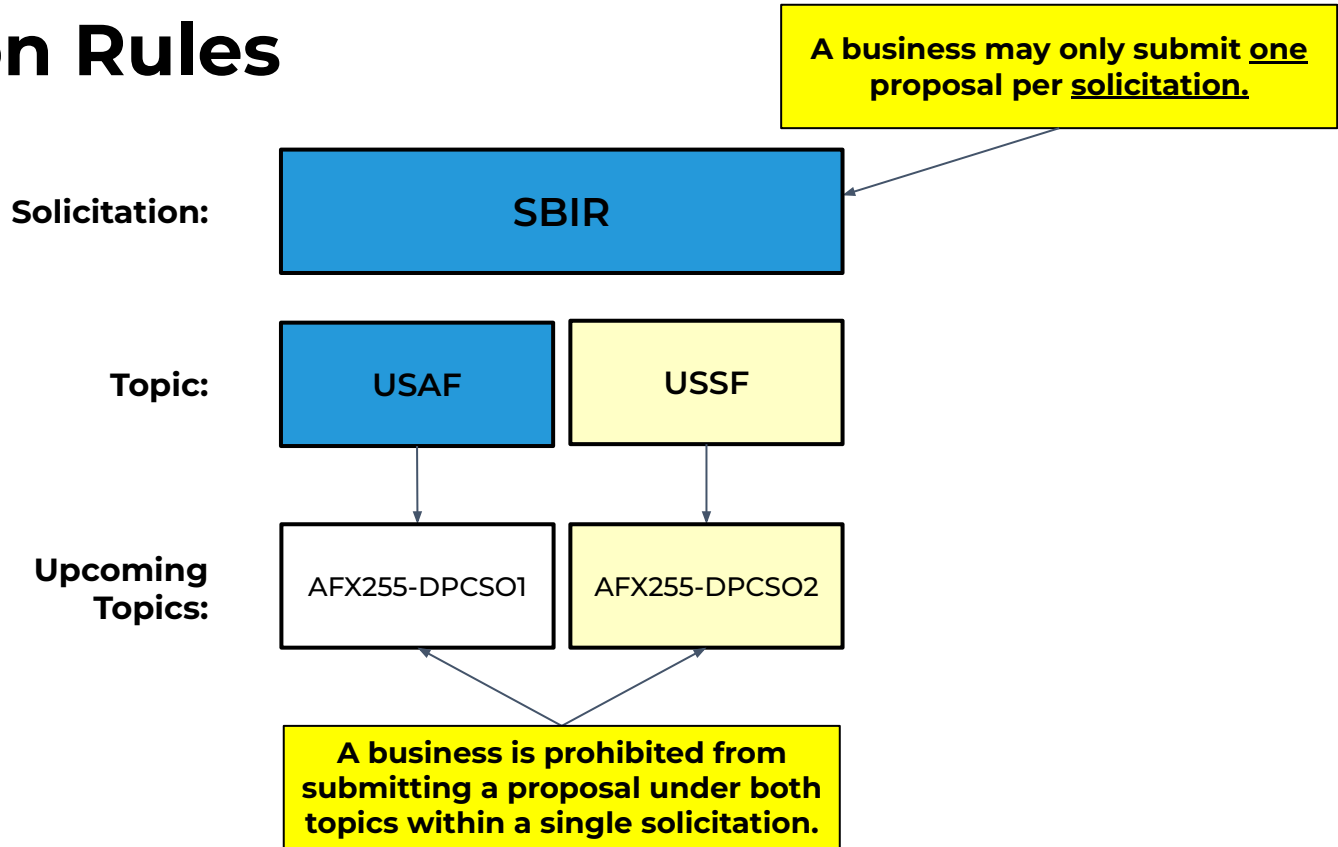

Space Open Topic D2P2

AFX255-DPCSO2 (USSF)

05 Feb 2025: DAF begins accepting proposals

06 March 2025: Full proposals due no later than 12:00 p.m. ET

Period of Performance: 21 months

Max Award: \$1.25M

Customer memorandum is required

All proposals must be prepared and submitted through the Department of Defense (DOD) SBIR/STTR Innovation Portal (DSIP)

<https://www.dodsbirsttr.mil/>

Phase I-Like Feasibility Study

- Direct to Phase II (D2P2) awards are granted to continue the research and development (R&D) from prior non-SBIR research and feasibility studies, aka 'Phase I-like effort'.
- Proposals should demonstrate sufficient technical progress or problem-solving results to warrant more extensive Research Development Test and Evaluation (RDT&E) via a comprehensive, detailed description of previous efforts.
- **Feasibility documentation cannot be based upon or logically extend from any prior or ongoing federally funded SBIR or STTR work.**

What is Research or Research & Development (R/RD)?

1. A **systematic study** directed toward **greater knowledge or understanding of the subject studied**
2. A **systematic study** directed specifically toward **applying knowledge and innovation to meet a recognized but unmet need**
3. A **systematic application of knowledge and innovation** toward the production of useful materials, devices, and systems or methods, **including design, development, and improvement of prototypes and new processes** to meet specific requirements
Includes **ALL** fields (physical sciences, engineering, etc.)

Why Does R/R&D Matter to SBIR/STTR Applicants?

SBIR/STTR programs are funded by RDT&E appropriations. Use of these funds is governed by federal financial law. Therefore, proposed projects must meet certain definitions and requirements to be eligible for SBIR/STTR funding.



R/R&D concerning COTS & NDIs

Items purchased directly from a commercial source that can be utilized without alteration through design and development, or without modification, are commercial off-the-shelf (COTS) or nondevelopmental items (NDI). This includes ready-to-use software, training services, and ready-to-use products.

COTS and NDIs by themselves are not suitable for SBIR/STTR funding.

****HOWEVER****

There may be exceptions if:

- The end item requires design and development in order to accept the COTS/NDI
- The COTS/NDI are required for RDT&E test purposes
- The proposal involves significant modification of COTS/NDI
 - To satisfy user requirements
 - Develop a capability

Source:7000.14-R, Financial Management Regulation, Volume 2A

Overall R/R&D Suggestions

- Demonstrate completion of R/R&D through means not solely based on previous efforts under the SBIR/STTR Programs to establish Phase II proposal feasibility based on criteria provided in the D2P2 topic descriptions
- **Feasibility documentation cannot be based upon or logically extend from any prior or ongoing federally funded SBIR or STTR work.**
- Ensure your proposal is explicit in explaining the RDT&E work you will be accomplishing
- Ensure your proposal does not lump R&D costs under licensing to provide clarity to the actual costs

D2P2 Proposal Structure

- **Vol 1: Proposal Cover Sheet (SAM, UEI, CAGE, Abstract, etc)**
 - Addressed in Part I, Commercial Solutions Opening Preface
- **Vol 2: Technical Volume**
 - Mandatory white paper, 15 page maximum, excluding table of contents and glossary (pages in excess NOT reviewed)
 - Non-Proprietary Work Plan and Commercialization Plan Outline
- **Vol 3: Cost Volume**
 - System formatted inputs
- **Vol 4: Company Commercialization Report (CCR)**
 - Follow solicitation instructions for Volume 4
 - CCR information is maintained and report is generated via sbir.gov
 - CCR is uploaded to DSIP as part of the proposal submission process, as applicable

**Reference actual solicitation(s) for full list of required & recommended documentation*

***Available via [Open Topic webpage](#) and as attachment to each solicitation in DSIP*

D2P2 Proposal Structure (Cont'd)

- Vol 5: Supporting Documents

- **MANDATORY customer memorandum (CM)** on required template**
- **TRI Attachment 3:** Regulatory Compliance Initial Safety Assessment Form
- Always refer back to the solicitation for required attachments



- Vol 6: Fraud, Waste, and Abuse Training

- **Vol 7: Disclosures of Foreign Affiliations or Relationship to Foreign Countries**

- The corporate official cannot certify and submit the full proposal until Volume VII webform is fully completed and submitted.

IMPORTANT:
Proposals that do not include properly prepared Attachments 3 and Vol 7 will also be deemed noncompliant and will not receive an evaluation.

**Reference actual solicitation(s) for full list of required & recommended documentation*

***Available via [Open Topic webpage](#) and as attachment to each solicitation in DSIP*

Customer Memorandum Signatures



- 3 CAC-enabled, digital signatures required (Customer, End-User, & TPOC) on a single memorandum
- Must be government (either Military or Civilian)
- FFRDC/Support contractors MAY NOT SIGN
- Customer or end-user may be non-DAF member from a DoD joint org
- TPOC MUST be a DAF (USAF or USSF) member in all cases

Customer/End-user may be from same organization, but must not be the same person.

Your proposal is limited to ONE completed memorandum

<p>20 Customer (FIRST MI LAST, RANK/GRADE, USAF)</p> <p>John Smith, GS-14, USAF</p> <p>↓ NOTE: A CAC-enabled, digital signature is required here AND in the field to the right.</p> <p>Smith.John n.111111</p> <p>Digitally signed by John Smith 111111 Date: 2023.08.08 12:18:25 -04'00'</p>	<p>21 End-User (FIRST MI LAST, RANK/GRADE, USAF)</p> <p>Jane Doe, Maj, USAF</p> <p>↓ NOTE: A CAC-enabled, digital signature is required here AND in the field to the left.</p> <p>Doe.Jane .222222</p> <p>Digitally signed by Jane Doe 222222 Date: 2023.08.10 14:27:13 -04'00'</p>
<p>22 Primary TPOC Signature (FIRST MI LAST, RANK/GRADE, USAF)</p> <p>Good, Michael, SSgt, USAF</p> <p>↓ NOTE: A CAC-enabled, digital signature is required here.</p> <p>Good.Michael ael.333333</p> <p>Digitally signed by Michael Good 444444 Date: 2023.08.12 08:55:19 -04'00'</p> <p>By signing this memorandum, you acknowledge you understand, accept, and will abide by the full terms and conditions outlined in the TPOC Designation Section.</p> <p>23 If you are actively planning to change jobs, PCS, or retire within the next 6 months, please advise your TPOC to support this effort.</p>	

Must be a DAF member in all cases.

**Images are for educational purpose only.*

Always reference afwerx.com for current memorandum language and requirements.

Customer Memorandum

Potential Grounds For Disqualification



Your proposal is limited to a single customer memorandum with three digital, CAC-enabled signatures

- Multiple memorandums with individual signatures are NOT accepted and will result in disqualification
- Scans, photos, and image reproductions of the form are NOT accepted as they do not allow for digital signature verification
- Avoid using Adobe Distiller to complete or modify the form - we suggest using Adobe Acrobat to mitigate data corruption issues

Failure to comply with these requirements may be grounds for disqualification.

**Images are for educational purpose only.*

Always reference afwerx.com for current memorandum language and requirements.

General Advice

Submission Requirements

- All eligible offerors must be qualifying, registered small businesses in SAM.gov prior to award, we suggest **registering early to avoid delays!**
- This solicitation is for **Direct-to-Phase II only**
 - Max contract terms of \$1.25M, 21 months period of performance
- Complete proposals must be submitted via the Defense SBIR/STTR Innovation Portal (DSIP)
 - Proposals cannot be pre-read or recommended for submission
 - No email or other non-DSIP submissions will be received
- Must be RDT&E activities
 - Not services or procurement
- Fraud, Waste, and Abuse training - Volume 6
 - Must be completed by one DSIP firm user with read/write access (proposal owner, corporate official, or firm admin) on behalf of the firm
- **Proposals that do not meet submission requirements will not be accepted**

General Advice Cont.

Common Causes for Non-Selection

- Exceeding Cost or Duration Limits - \$1.25M and 21 months max
- SAM.gov Registration - firms must have an active registration, we suggest registering early to avoid delays!
- Missing Documentation - all required volumes and attachments must be included per the solicitation
 - Invalid or missing Customer Memo
 - Must have THREE valid signatures
 - Must use the most recent version that includes the current solicitation on the header
 - Unsigned or missing Volume VII: Disclosures of Foreign Affiliations or Relationships to Foreign Countries
 - Missing or incomplete Attachment 3: Regulatory Compliance Initial Safety Assessment
- Multiple Submissions
 - A small business concern may only submit **one** proposal under each solicitation
 - A small business concern is prohibited from submitting a proposal under both topics (i.e. submit to both the AF and SF topics of a single D2P2 SBIR solicitation)
 - If more than one proposal from a small business concern is received for a single solicitation, **only the most recent proposal to be certified and submitted prior to the submission deadline** will be eligible for evaluation

General Advice Cont.

Common Causes for Non-Selection

- Minimum Performance Percentage of Work - Not allocated properly
 - Small business must perform 50% or more of the work (SBIR)
- R/R&D - Work, as proposed, does not meet the definition of R/R&D required for funding
 - Proposed work is not R/R&D
- Data Rights Assertions
 - Proposal claims data rights assertions without including a *Data Rights Assertions* table (as found in DFARS 252.227-7017) in Volume V, Supporting Documents, of the proposal.

General Advice cont.

Common Proposal Issues

- Not addressing solicitation requirements, particularly evaluation criteria (refer to CSO solicitation covering Selection Methodology and Evaluation Criteria)
- Unclear proposed benefit to the government customer (see solicitation: Table 1: Technical Volume Content Description)
- Inconsistent milestones/timelines and proposal not matching Customer Memorandum (see solicitation: Table 2: Non-Proprietary Phase II Work Plan Outline)
- COTS/Software licenses appropriateness for proposed effort (see solicitation)

What's Next?

- **Proposals due Thursday, 06 March 2025 @ Noon ET**
 - All proposals must be submitted via DSIP (<https://www.dodsbirsttr.mil/>)
 - Do not wait until the end of the submission period to submit proposal materials
- **Be familiar with Evaluation Criteria**
 - Technical approach
 - Defense need
 - Commercialization potential
- **Questions must be answered publicly via DSIP Q&A or AMA webinars**
 - The solicitation is the final, authoritative source of info & requirements
 - Questions answered via email will be limited to non-substantive, administrative questions only, e.g. proposal formatting, proposal submission instructions, etc.

Solicitation Resources

Contracting Officer: Mr. Ryan DeBonis

Program Manager: Rachel Braun

For technical questions, use DSIP Q&A section

<https://www.dodsbirsttr.mil/submissions/baa-schedule/active-baa-announcements>

Customer Memorandum 25.5 D2P2 Required Form and Regulatory Compliance Initial Safety Assessment can be found on [AFWERX.com](https://www.afwerx.com)

IMPORTANT: One memo with three digital signatures is required. Three memos with one signature each will not be accepted. Scans, photos, and image reproductions of the memo also not accepted.

28 Mar 24 Completing the Customer Memorandum: Open Topic Phase II and D2P2

[Webinar Recording](#)

[Webinar Presentation Slides](#)

Additional Resources

SBIR.gov Tutorials

<https://www.sbir.gov/tutorials/>

Defense SBIR/STTR Innovation Portal (DSIP) Tutorials

<https://www.dodsbirsttr.mil/submissions/learning-support/training-materials>

Defense SBIR/STTR Innovation Portal (DSIP) Home Page

<https://www.dodsbirsttr.mil>



AFWERX · SPACEWERX

Questions?